

Sorption of the Simplest Carboxylic Acids on Clay-Like Mineral Glaucosite: Reduction of Integral Toxicity of Aqueous Solutions

L.E. Tsygankova^{1,*}, M. Vigdorowitsch², A.A. Uryadnikov¹, E.D. Tanygina¹, O.V. Alyokhina¹ and M.N. Uryadnikova¹

¹Derzhavin State University, ul. Internatsyonalnaya, 33, Tambov, 392000, Russian Federation

²Angara GmbH, In der Steele 2, 40599 Düsseldorf, Germany

Abstract: The integral toxicity of solutions of a number of carboxylic acids was estimated by measuring their chemical oxygen consumption (COC) and the biochemical oxygen demand for the biodegradation of substances due to microorganisms (BOD_5). The analytical dependences of COC and BOD_5 as well as of their ratio for these compounds on concentration were determined. The values of COC and BOD_5 for a number of acid solution mixtures were measured. The coefficient that indicates biodegradability of substances has been calculated. The chemical consumption of oxygen by solutions of organic acids is shown to increase with the transition from lower to higher homologues and with increase in the concentration of the solution.

The kinetics and degree of removal of organic acids out of solutions due to sorption on the clay-like mineral, glaucosite, have been studied. Glaucosite that is the natural sorbent is characterized by a high adsorbing power in solutions of organic acids under both stationary and non-stationary conditions. However, adsorption becomes complicated as complexity of the organic acid molecule structure grows. To achieve more comprehensive removal of acids out of solutions, one reduces flow rate and increases thickness of the sorbent layer.

Keywords: Organic acids, biodegradability, oxygen consumption, sorption, glaucosite.

INTRODUCTION

Approaches to assessment of substance toxicity are based on the normative values for individual compounds, namely MPC_i (maximum permissible concentration in a work area to be averaged out daily, atmospheric air, a one-time maximum for the gas phase) or LC_{50} (lethal concentration), LD_{50} (lethal dose) [1- 3]. These quantities are the basis for determination of the hazard class of substances. For water-soluble products, the maximum permissible concentration is applied to water for cultural, domestic and domestic drinking purposes as well as to water for fishery purposes. The MPC values have at least two significant drawbacks, since they are not biological constants. Firstly, those adopted in different countries can vary considerably, even 10fold and more. Secondly, MPC s for pure substances do not say much about the toxicity of their solutions whose concentrations can vary within a wide range of characteristics depending on specific conditions and productions. However, there are no generally accepted indicators that would characterize an integral toxicity of solutions of chemical compounds of various classes in a wide range of concentrations.

A simple and effective method to estimate the integral toxicity of solutions of hazardous substances is

to measure the chemical oxygen consumption (COC) and/or biochemical oxygen demand (BOD_i , where i corresponds typically to either 5 or 20 days) for biodegradation of substances by microorganisms. Estimation of these values is quite simple, does not require special medical education and is possible in any chemical or biochemical laboratory. Furthermore, for the most time-consuming parameter out of these two, BOD_5 , it takes only 5 days, whereas for evaluation of MPC_i one needs 6 months or more. MPC_i cannot be used to determine toxicity of solutions and biodegradability of harmful substances dissolved. However, biodegradability of substances in solutions is known to be characterized by the following relationship [4]:

$$A = BOD_5(\text{substance})/COC(\text{substance})$$

As an example, MPC (COC) for domestic water reads 30 mg O_2/L and MPC (BOD_5) 6 mg O_2/L in Russian Federation.

Analytical dependences of both COC and BOD_5 on concentration C_i of the substance can be often satisfactorily represented by a linear equation

$$COC_i = a_i + k_i C_i.$$

The aim of this study is to determine the integral toxicity characteristics of solutions of the simplest monobasic carboxylic acids as well as reduction thereof by sorption removal of acids out of solutions due to a clay-like mineral.

*Address correspondence to this author at the Derzhavin State University, Internatsyonalnaya Str., 33, Tambov, 392000, Russia; Tel: +7 4752 723655; E-mail: vits21@mail.ru

EXPERIMENTAL

The solutions of formic, acetic and butyric acids were studied in a wide range of concentrations from 0.0001 to 0.01 M. To evaluate COC by the procedure described in [5], 10 ml of the 0.25 M solution $K_2Cr_2O_7$, 0.44 g mercury (II) and silver sulfates were added to 20 ml of the sample. While stirring, 30 ml concentrated sulfuric acid was added and refluxed for 2 hours. Upon cooling, 100 ml distilled water, 5 drops of ferroin were added and the excessive $K_2Cr_2O_7$ was titrated with the Mohr salt solution. Simultaneously, a blank determination was performed with 20 ml distilled water. The results were calculated according to formula

$$COC = [8(V_{MX} - V_M) C_M \cdot 1000]/V,$$

where V_{MX} , ml, is the volume of the Mohr salt solution used for titration in the blank test and V_M , ml, for titration of the sample, C_M , mol-equiv./L, is concentration of the Mohr salt solution, V , ml, is volume of water used for determination, and the mass of mole-equivalent oxygen is equal to 8.

Determination of BOD_5 was carried out in accordance with [6]. The estimation of the BOD_5 value is based on iodometric determination of oxygen in the initial or diluted water sample before and after its incubation for 5 days under standard conditions ($20^\circ C$, no light and no air). The mass concentration of oxygen dissolved in water was determined by the equation

$$C_x = 8 C_T V_T V \cdot 1000 / [50(V - V_1)],$$

where C_x , mg/L, is concentration of dissolved oxygen in the water sample analyzed, C_T , mole-equiv./L, is concentration of sodium thiosulfate solution, V_T , ml, is volume of sodium thiosulfate solution, used for the titration, V denotes capacity of the bottle to determine BOD_5 , ml; V_1 , ml, is total volume of the solution of manganese chloride and potassium iodide added to the bottle when fixing dissolved oxygen; for factor 8 s. above.

Biochemical oxygen consumption BOD_5 , mg O_2/L , both for undiluted samples and diluting water is calculated by the equation

$$BOD_5 = C_{x1} - C_{x2}$$

where C_{x1} , mg/L, is concentration of dissolved oxygen in the sample of water analyzed or in the sample of diluting water for incubation; C_{x2} , mg/L, is concentration of oxygen dissolved in the sample of water analyzed or in the sample of diluting water after 5 days of incubation.

The natural sorbent, a 95% glauconite concentrate, obtained by enriching the natural mineral of the Bondar (Tambov region in Russia) deposit, was used. Glauconite is characterized by a high adsorbing power with respect to heavy metal cations, phenol, cations of hardness [7, 8] like other clay-like minerals [9,10]. It was preliminarily treated by the 0.1 M NaOH solution (the ratio glauconite/solution 1:20 wt.) for 20 minutes, then the alkali was washed out with distilled water and then the same procedure was carried out in 1 M HCl followed by washing the acid out. Then the sorbent was transformed into the Na form in a 3 M NaCl solution for one hour with a successive washing the chlorine ions out [7]. Water with a negative reaction to Ca^{2+} and Mg^{2+} , Cl^- and SO_4^{2-} was used. Furthermore, the glauconite concentrate was pre-chemically treated with heat $300^\circ C$ for 20 min.

Under steady-state conditions, sorption was carried out out of solutions stirred by a magnetic stirrer. The volume of the solution in each experiment was 100 ml, the mass of the sorbent was 1 and 10 g. At regular intervals (20, 60 min), the suspensions were filtered and the filtrate was used to determine the COC.

Sorption studies were also carried out under dynamic conditions in a bed porous system consisting of a glass column 20 cm high and internal diameter 2.6 cm (Figure 1). At the bottom of the column a cellulose acetate filter was placed. The height of the adsorbent layer was equal to 0.5 and 1.0 cm. The solution flow rate in the column was the subject to flow rate control. The linear outflow rate l , m/h, calculated as $l = v/s$, where v , m^3/h , stands for the volume rate and s for the cross-sectional area of the column, was 0.3 and 0.5 m/h. The eluate was collected at regular intervals (20, 40, 60 min) and used to determine the COC.

RESULTS AND DISCUSSION

Dependence of COC on logarithm of concentration (C , mol/L) for acetic and butyric acid solutions is linear (Figures 2 and 3) and can be expressed by the equations

$$COC_{CH_3COOH} = 584,40 + 144,55 \log C$$

$$COC_{C_3H_7COOH} = 1273,35 + 302,97 \log C$$

Such a dependence for solutions of formic acid in the concentration range studied cannot be satisfactorily approximated by a single straight line (Figure 2).

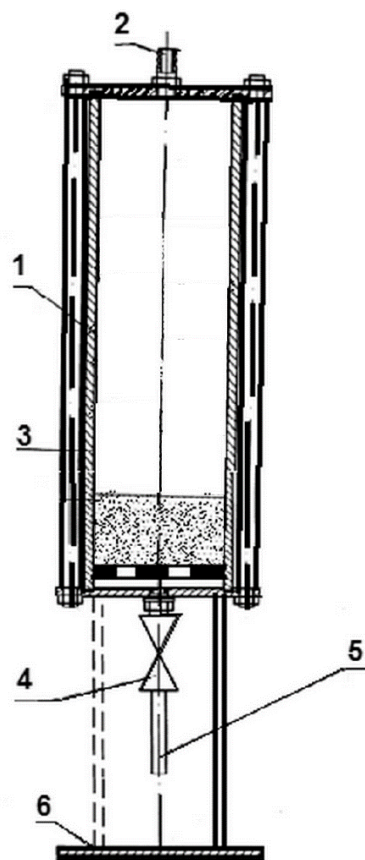

Figure 1: Scheme of column system. 1 – glauconite, 2 – inlet, 3 – column body, 4 – flow rate control, 5 – outlet, 6 – stand.

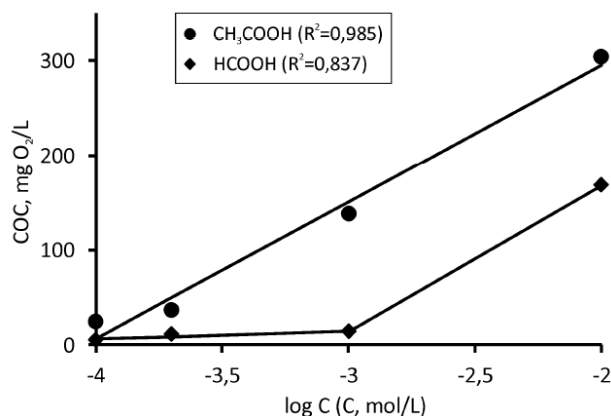

Figure 2: Dependence of COC on logarithm of concentration (C , mol/L) for the solutions of acetic and formic acids.

Logarithmic dependences of $\log \text{COC}$ on $\log C$ for all the acid solutions studied were also analyzed and successfully approximated by straight lines (Figure 4) according to the following equations:

$$\text{COC}_{\text{HCOOH}} = 3548.1 \cdot C^{0.71}$$

$$\text{COC}_{\text{CH}_3\text{COOH}} = 4677.4 \cdot C^{0.56}$$

$$\text{COC}_{\text{C}_3\text{H}_7\text{COOH}} = 5754.4 \cdot C^{0.44}$$

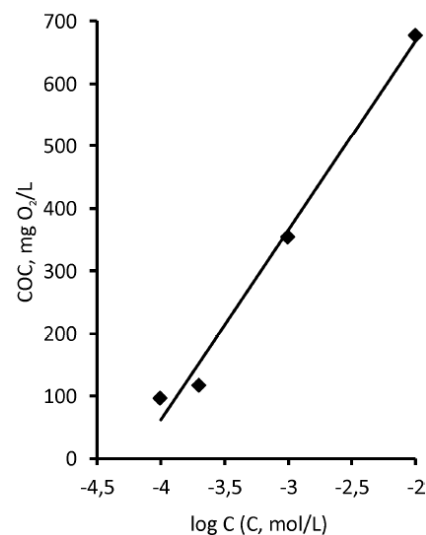

Figure 3: Dependence of COC on logarithm of concentration (C , mol/L) for the solutions of butyric acid. $R^2=0,988$.

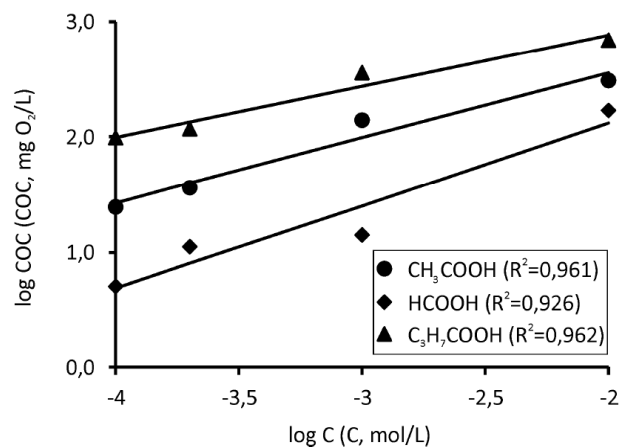

Figure 4: The logarithmic dependence of COC on concentration (C , mol/L) for the solutions of carboxylic acids.

The oxygen chemical consumption by the acid solutions increases in the series:



The data on measurements of COC for the mixtures of acid solutions are given in Table 1.

Table 1: COC by Acid Solutions Mixtures

Mixture composition	COC, mg O ₂ /L
0.001 M CH ₃ COOH : 0.001 M HCOOH	27
0.001 M CH ₃ COOH : 0.002 M HCOOH	32
0.002 M CH ₃ COOH : 0.001 M HCOOH	17

Mixtures of the solutions of acetic and formic acids with 0.001 M concentration are characterized by COC

almost twice as much as that for the formic acid solution, but 5 times as low as that for the acetic acid solution. When the ratio of these concentrations is 1:2, there are no noticeable changes in the COC value compared to the previous case, and with ratio 2:1 the value of COC becomes smaller. Therefore, the presence of formic acid in a mixture with acetic acid promotes a significant reduction in the chemical consumption of oxygen compared to the corresponding solution of acetic acid.

The values of the BOD_5 of the acid solutions studied are shown in Figure 5.

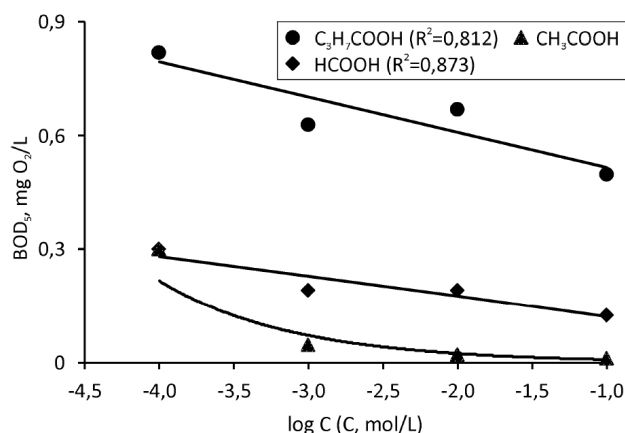

Figure 5: Dependence of BOD_5 on logarithm of concentration for the solutions of carboxylic acids.

The solutions of butyric acid are characterized by the highest biological consumption of oxygen, those of acetic acid by the lowest one and of formic acid are intermediate.

To estimate BOD_5 of mixtures of the acid solutions studied, 0.1 M solutions of HCOOH and CH₃COOH were used, which in certain amounts were transferred to a 1 L volumetric flask, then the volume was adjusted to 1 L with distilled water. The results are presented in Table 2.

Table 2: The Values of BOD_5 of a Number of Mixtures of Formic and Acetic Acids

Mixture composition	BOD_5 , mg O ₂ /L
10 ml HCOOH : 100 ml, CH-3.COOH (1:10)	1,48
10 ml HCOOH : 20 ml, CH-3.COOH (1:2)	0,64
10 ml HCOOH : 10 ml, CH-3.COOH (1:1)	0,7
100 ml HCOOH : 10 ml, CH-3.COOH (10:1)	9,4

It follows from Table 2 that a 10fold increase in the amount of acetic acid in a mixture as compared to

HCOOH approximately doubles BOD_5 and of formic acid while compared to acetic acid increases BOD_5 more than 10fold. Thus, mixtures of acid solutions are characterized by a higher BOD_5 value than solutions of individual acids.

It was previously indicated, the use of COC and BOD_5 makes it possible to calculate coefficient A whose value characterizes a possibility of biodegradability of substances in a solution (Table 3). The larger the value of A is, the more liable the substance to biodegradation in a solution appears to be.

Table 3: The Value of A for Solutions of Carboxylic Acids

Acid	$A = BOD_5/COC$ at C_{acid} , M		
	0.01	0.001	0.0001
HCOOH	0.0011	0.013	0.06
CH ₃ COOH	0.00006	0.00034	0.012
C ₃ H ₇ COOH	0.00099	0.0018	0.0084

All acids are hard to biodegrade. Biodegradability of the acid solutions decreases in the direction:

$$0.0001 \text{ M HCOOH} > 0.001 \text{ M HCOOH} > 0.0001 \text{ M CH}_3\text{COOH}$$

Figure 6 shows the logarithmic dependence of A on concentration of the acid solutions studied. For all acids, this relationship can be successfully approximated by straight lines according to the following equations:

$$\log A_{\text{HCOOH}} = -4.55 - 0.83 \log C$$

$$\log A_{\text{CH}_3\text{COOH}} = -6.70 - 1.17 \log C$$

$$\log A_{\text{C}_3\text{H}_7\text{COOH}} = -4.05 - 0.49 \log C$$

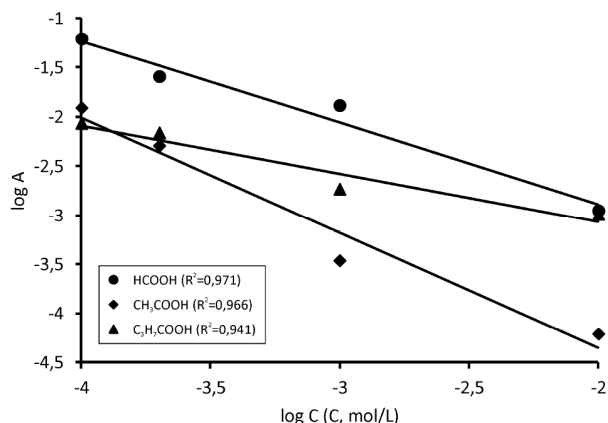

Figure 6: The logarithmic dependence of A on concentration of solutions of carboxylic acids.

Table 4: Reduction of COC by a Number of Acid Solutions after Removal of Acid Out of their Solution by Means of Glauconite in Stationary Conditions

Acid solution	Mass of the sorbent for 100 ml of solution, g	COC, mg O ₂ /L	C, M after sorption
0,01 M CH ₃ COOH (20 min stirring)	absent	304	
	1	300	
	10	254,8	0.0056
0,01 M CH ₃ COOH (60 min stirring)	1	195	0.0020
	10	160	0.0010
0,001 M CH ₃ COOH (20 min stirring)	absent	137,5	
	1	19,2	0.0001
0,01 M HCOOH (20 min stirring)	absent	168	
	1	86,4	0.004
	10	88,2	0.004
0,01 M HCOOH (60 min stirring)	1	30	0.0012
	10	30	0.0012
0,001 M HCOOH (20 min stirring)	absent	14,0	
	1	0	0

Let us consider the data on the reduction of COC by the acid solutions after removal thereof from the solution by means of glauconite in stationary conditions (Table 4).

Under steady-state conditions, an increase in both the mass of the adsorbent and contact time promotes adsorption of acids out of aqueous solutions. With an adsorbent mass 10 g and contact time 60 minutes, the concentration of the initial 0.01 M acetic acid solution decreases by a factor of 1/10. At lower initial concentration (0.001 M), a 10fold decrease in concentration occurs with glauconite mass 1 g and contact time 20 minutes. The concentration of the initial 0.01 M solution of formic acid is reduced by a factor of 2.5 with contact time 20 min, regardless of the mass of adsorbent (1 and 10 g), out of the 0.001 M solution the acid is absorbed almost completely during 20 min with an adsorbent mass 1 g.

The sorption studies were also carried out under dynamic conditions.

Tables 5 and 6 show the data for COC for formic acid upon being adsorbed under dynamic conditions.

Under dynamic conditions with a solution flow rate 0.3 m/h and a sorbent layer thickness 1 cm for a duration of 20 to 60 min, complete adsorption of formic acid out of 0.01 M solution is observed. With flow rate 0.5 m/h complete absorption is observed in 40 minutes. A decrease in the thickness of the sorbent layer to 0.5 cm results in a complete adsorption of formic acid only for 20 minutes. The decrease in the initial concentration of formic acid to 0.001 M is characterized by the fact that a complete removal of acid from the solution sorbent layer thickness 1 cm at both rates is observed in 60 min, and with layer height 0.5 cm in 40 min. In 60 min in the effluent solution the acid concentration

Table 5: The Effect of Sorption Duration, Flow Rate and Sorbent Layer Thickness on COC by Means of Glauconite Sorption Removal of HCOOH Out of the Initial 0.01 M Solution. COC of the Initial Solution is 168 mg O₂/L

Time, min	COC, mg O ₂ /L			
	u = 0,3 m/h		u = 0,5 m/h	
	h = 0,5 cm	h = 1 cm	h = 0,5 cm	h = 1 cm
20	0	0	0	0
40	10	0	25	0
60	20	0	30	10

Table 6: The Effect of Sorption Duration, Flow Rate and Sorbent Layer Thickness on COC by Means of Glauconite Sorption Removal of HCOOH Out of the Initial 0.001 M Solution. COC of the Initial Solution is 14 mg O₂/L

Time, min	COC, mg O ₂ /L			
	u = 0,3 m/h		u = 0,5 m/h	
	h = 0,5 cm	h = 1 cm	h = 0,5 cm	h = 1 cm
20	0	0	0	0
40	0	0	0	0
60	5	0	5	0

Table 7: The Effect of Sorption Duration, Flow Rate and Sorbent Layer Thickness on COC by Means of Glauconite Sorption Removal of CH₃COOH from the Initial 0.0001 M Solution. COC of the Initial Solution is 24.5 mg O₂/L

Time, min	COC, mg O ₂ /L			
	u = 0,3 m/h		u = 0,5 m/h	
	h = 0,5 cm	h = 1 cm	h = 0,5 cm	h = 1 cm
20	0	0	5	5
40	10	15	20	15
60	22,5	30	25	35

reaches 0.0003 M. Thus, formic acid is completely removed out of the 0.01 M solution at sorbent bed height 1 cm and flow rate 0.3 m/h in 60 minutes, and it is completely removed out of 0.001 M solution at the same flow rates for the same time.

Acetic acid is adsorbed by the adsorbent out of the flowing solutions much slower than the formic acid. Thus, for sorbent layer thickness 1 cm at both studied flow rates the acid concentration decreases in 20 minutes from 0.01 down to 0.002 M and in 40 minutes down to 0.006 M, i.e. adsorption deteriorates in time. With the adsorbent bed height 0.5 cm the removal of the acid is even slower i.e. in 60 minutes an untreated solution flows in fact out.

The solution with concentration 0.0001 M at flow rate of 0.3 m/h at both values of thickness of the sorbent layer is completely purified of acetic acid in 20 minutes, but in 40 minutes the effluent solution has already a concentration only about half of that for the original solution, and in 60 minutes it practically has the initial concentration (Table 7). At a rate of 0.5 m/h, the adsorption becomes still slower.

Thus, for a better removal of acetic acid out of the solutions one reduces the flow rate and increases the thickness of the sorbent layer. The lower the concentration is, the more comprehensive the removal appears to be.

CONCLUSION

The studies presented have shown that the chemical consumption of oxygen by solutions of the organic acids increases with the transition from the lower to higher homologues and with an increase in concentration of the solution. Formic acid is safe for ponds at a concentration of 0.001 mol/L and lower, acetic acid at concentration 0.0001 mol/L and lower, butyric acid remains hazardous at such concentrations. The solutions of butyric acid are characterized by the highest biological consumption of oxygen, solutions of acetic acid by the lowest one, solutions of formic acid occupy an intermediate position.

All the acids studied are hard to biodegrade. Biodegradability of the acid solutions decreases in the direction:

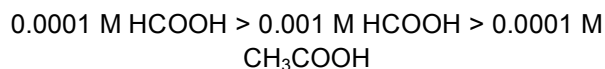

It is shown that the organic acids studied can be removed out of the solutions using a clay-like sorbent glauconite in stationary and dynamic conditions.

ACKNOWLEDGEMENTS

The study was conducted with funding under the RFFFR grant № 17-43-680258/17p_a.

REFERENCES

- [1] Hygienic. Hygienic requirements for quality assurance atmospheric air in populated areas: SanPin 2.1. 6.1032 – 01. Moscow: IITS of the Ministry of Health of Russia 2001.
- [2] Maximum. Maximum permissible concentration (MPC) of chemical substances in soil: GN 2.1.7. 2041 - 06. Moscow: IITS of the Ministry of Health of Russia 2006.
- [3] Lazarev NV, Levina EN. Harmful substances in industry. Moscow: Chemistry 1976.
- [4] Vigdorovich VI, Shel N, Zarapina IV. Theoretical basis, technology and technology of neutralization, processing and recycling of waste. Moscow: CARTEK 2008.
- [5] Methodological RD 52.24.421-95. Methodological guidelines for the determination of COC in waters. Rostov n/D 1995.
- [6] Methodologica RD 52.24.420-95. Methodological guidelines for the determination of BOD in waters by bottle method. Rostov n/D 1995.
- [7] Vigdorovich VI, Tsygankova LE, Esina MN, Uryadnikov AA, Shel NV. Calculation of the dynamic sorbent capacity in the presence of two sorbates. J Water Process Eng 2017; 20: 180-6.
<https://doi.org/10.1016/j.jwpe.2017.11.002>
- [8] Vigdorovich VI, Tsygankova LE, Akulov AI. Phenol extraction from aqueous solutions by glauconite. Sorbtsyonnye i chromatographicheskie processy (Rus) 2010; 10: 500-5.
- [9] Zhu L, Zhu R. Simultaneous sorption of organic compounds and phosphate to inorganic–organic bentonites from water. Sep Purif Technol 2007; 54: 71-6.
<https://doi.org/10.1016/j.seppur.2006.08.009>
- [10] Anirudhan TS, Ramachandran M. Surfactant-modified bentonite as adsorbent for the removal of humic acid from waste waters. Appl Clay Sci 2007; 35: 276-81.
<https://doi.org/10.1016/j.clay.2006.09.009>

Received on 27-07-2018

Accepted on 17-12-2018

Published on 21-12-2018

DOI: <https://doi.org/10.6000/1929-5030.2018.07.07>